

Series 1100HD

Split MEGALUG® Bell Restraint Harness for Existing Ductile Iron Pipe

All EBAA products intended for installation on ductile iron pipe are designed for and limited to use on ductile iron pipes that comply with the requirements of ANSI/AWWA C151/A21.51 and have a Brinell Hardness or equivalent measurement value that does not exceed 230BHN. **These requirements apply to the entire pipe wall profile at all restraining wedge engagement points and to the full penetration depth of each restraining wedge.***

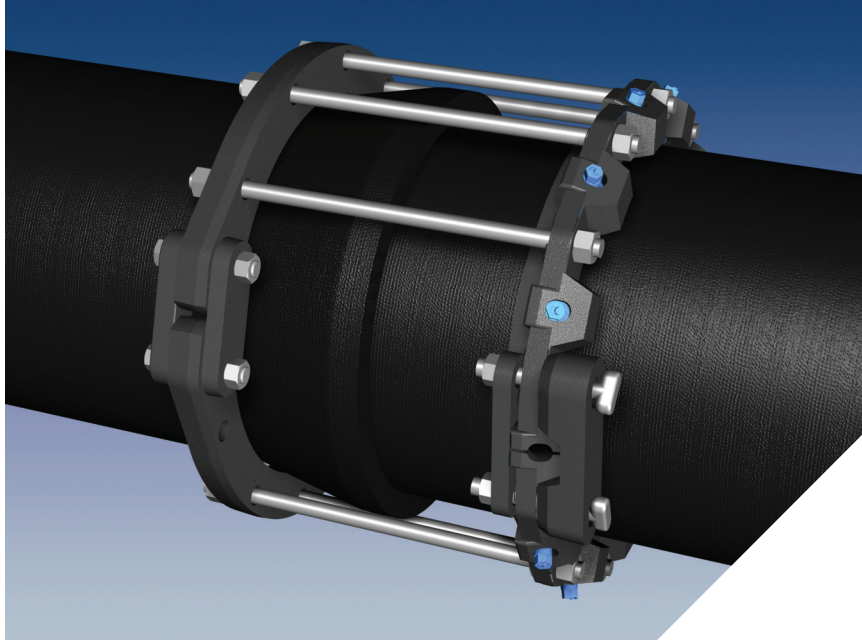

Series 1116HD on 16 inch Ductile Iron Pipe.

Features and Applications:

- For use on Existing Ductile Iron Pipe at Pipe to Pipe Push On Joints
- MEGA-BOND® Restraint Coating System
- Minimum 2 to 1 Safety Factor
- Split Design for Ease of Installation
- Constructed of ASTM A536 Ductile Iron

For use on water or wastewater pipelines subject to hydrostatic pressure and tested in accordance with either AWWA C600 or ASTM D2774.

Pressure Ratings Table

Nominal Pipe Size	Series Number	Approximate Shipping Weight	Thrust Rods (Quantity - Size)	Pressure Rating (PSI)
3	1103HD	9.50	4 - 5/8 x 12	350
4	1104HD	23.50	4 - 3/4 x 13	350
6	1106HD	33.00	4 - 3/4 x 13	350
8	1108HD	41.00	4 - 3/4 x 13	350
10	1110HD	63.16	4 - 3/4 x 18	300
12	1112HD	77.06	4 - 3/4 x 18	300
14	1114HD	136.15	6 - 3/4 x 18	300
16	1116HD	143.92	8 - 3/4 x 18	300
18	1118HD	160.41	8 - 3/4 x 18	200
20	1120HD	187.08	10 - 3/4 x 18	200
24	1124HD	252.89	12 - 3/4 x 18	200
30	1130HD	492.20	16 - 1 x 18	200
36	1136HD	546.30	20 - 1 x 18	200
42	1142HD	964.30	24 - 1 1/4 x 28	175
48	1148HD	1,270.90	28 - 1 1/4 x 28	175
54	1154HD	1,923.56	32 - 1 1/4 x 32	250

NOTE: For applications or pressures other than those shown, please contact EBAA for assistance.

Sample Specification

Restraint for existing bell joints found on ductile iron pipes shall consist of the following: The restraints shall be manufactured of ductile iron conforming to ASTM A536. The split restraint rings, incorporating a plurality of individually-actuating gripping surfaces, shall be used to grip the pipe on either side of the bell, and a sufficient number of rods shall be used to connect each restraint to one another. The restraint devices shall be coated using MEGA-BOND. (For complete specifications on MEGA-BOND visit www.ebaa.com.) The combination shall have a minimum working pressure rating as shown in the adjacent table. The restraint shall be the Series 1100HD, as manufactured by EBAA Iron, Inc., or approved equal.

Submittal Reference Drawing

EBAA IRON

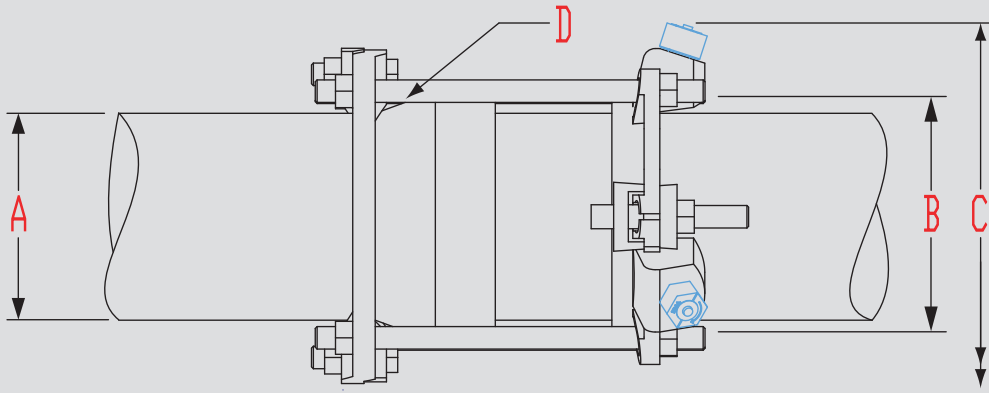

MADE IN USA

Nominal Pipe Size	Series Number	A Pipe O.D.	B Maximum Bell O.D. Cleared	C Casing Clearance (w/Nuts Off)	D Thrust Rods (Quantity - Size)
3	1103HD	3.95	5.40	9.06	4 - 5/8 x 12
4	1104HD	4.81	6.60	9.90	4 - 3/4 x 13
6	1106HD	6.90	8.60	12.00	4 - 3/4 x 13
8	1108HD	9.05	10.90	14.15	4 - 3/4 x 13
10	1110HD	11.10	13.10	16.20	4 - 3/4 x 18
12	1112HD	13.20	15.40	18.30	4 - 3/4 x 18
14	1114HD	15.30	17.90	21.88	6 - 3/4 x 18
16	1116HD	17.40	20.10	24.13	8 - 3/4 x 18
18	1118HD	19.50	22.40	26.50	8 - 3/4 x 18
20	1120HD	21.60	24.60	28.50	10 - 3/4 x 18
24	1124HD	25.80	29.10	33.38	12 - 3/4 x 18
30	1130HD	32.00	35.80	40.25	16 - 1 x 18
36	1136HD	38.30	42.60	46.75	20 - 1 x 18
42	1142HD	44.50	49.20	55.57	24 - 1 1/4 x 28
48	1148HD	50.80	56.00	61.87	28 - 1 1/4 x 28
54	1154HD	57.56	64.51	72.50	32 - 1 1/4 x 32

NOTE: Dimensions are in inches and are subject to change without notice.

Installation Instructions

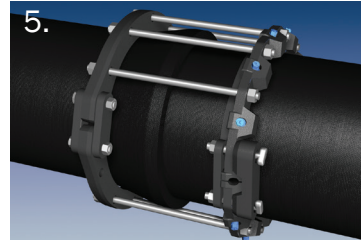
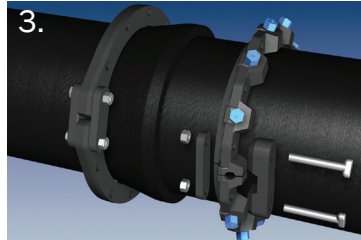
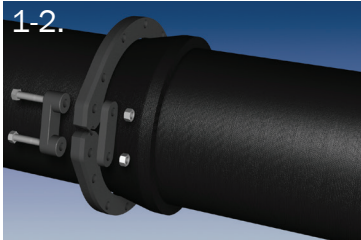

1. The Series 1100HD is designed for restraining existing ductile iron pipe, conforming to ANSI/AWWA C151/A21.51 (all thickness classes), push on pipe bells. It has a split restraint ring on the spigot and a split ring behind the bell.

All EBAA products intended for installation on ductile iron pipe are designed for and limited to use on ductile iron pipes that comply with the requirements of ANSI/AWWA C151/A21.51 and have a Brinell Hardness or equivalent measurement value that does not exceed 230BHN. **These requirements apply to the entire pipe wall profile at all restraining wedge engagement points and to the full penetration depth of each restraining wedge.***

2. Install the split ring behind the bell in the direction indicated on the casting. Tighten the clamp bolts to 90 ft-lbs.

*To learn more about this addendum, please visit: <https://ebaa.com/spec/dip>

3. Disassemble the split restraint ring then reassemble restraint on the spigot such that the bolt holes are in alignment and the distance between the rings is suitable for the tie bolt length with the lip of the restraint facing toward the bell. Allow enough room on the tie bolt to fully engage the nut with several threads showing.

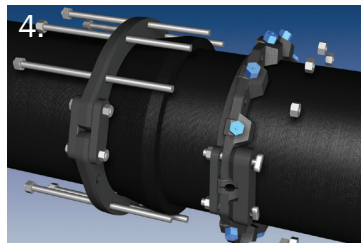

4. Install the tie bolts in each available bolt hole for maximum distribution of operating forces. Place nuts on the end of the tie bolts. Allow enough room on the tie bolt to fully engage the nut with several threads showing. Pull the restraint ring away from the joint until the slack is removed from the tie bolts.

5. Tighten the torque limiting twist off nuts in a clockwise direction (direction indicated by arrow on top of nut) until all wedges are in firm contact with the pipe surface. Continue tightening in an alternate manner until all of the nuts have been twisted off. Tighten the tie bolt nuts until the ring behind the bell is in firm contact with the back of the bell.

6. If removal is necessary; use the 5/8" hex heads provided. If reassembly is required, assemble the product in the same manner as indicated in the previous steps and tighten the wedge bolts to 90 ft-lbs.



EBAA IRON Sales, Inc.
 P.O. Box 857, Eastland, TX 76448
 Tel: (254) 629-1731
 Fax: (254) 629-8931
 (800) 433-1716 within US and Canada
contact@ebaa.com
www.ebaa.com