



Series 65PF10SS4

Restraint for IPS O.D. (Class) PVC Pipe at
Ductile Iron Fittings

CONTAINS BOTH DOMESTIC AND IMPORTED HARDWARE

Installation Instructions

1. This Series is designed for restraining PVC pipe (Series 15PF00 for AWWA C900 PVC pipe and Series 65PF00 for IPS O.D. (Class) PVC pipe) at ductile iron push-on bell fittings supplied with restraining.
2. Assemble the pipe joint per the pipe manufacturer's instructions.
3. Using the connecting rods to determine the proper restraint location, install both halves of the split restraint by tapping them into place. Allow enough room on connecting rods to fully engage the nuts. Make sure the complete ID of the restraint is touching the pipe before installing and tightening of side bolts. Side bolts are to be evenly tightened to 110 ft-lbs. of torque (60 ft-lbs. on 4 inch and 6 inch).
4. Tighten the connecting bolts until snug. Do not over tighten connecting bolts as to move the spigot further into the joint.

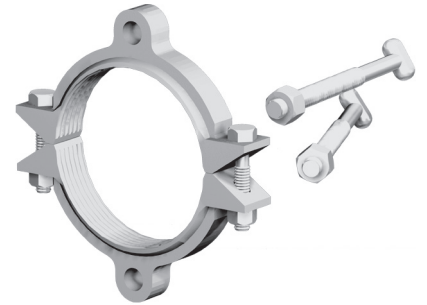

CONTENTS

Qty.	Description
1	10 inch Sized 6500 Split Restraint
4	3/4 in. by 8 in. Stainless Steel Tie Rods w/ Nuts

Restraints Made in The USA

For use on water or wastewater pipelines subject to hydrostatic pressure and tested in accordance with either AWWA C600 or ASTM D2774

APPROXIMATE SHIPPING WEIGHT: 33 lbs.

0120-C

Copyright 2021 © EBAA IRON, Inc. All Rights Reserved

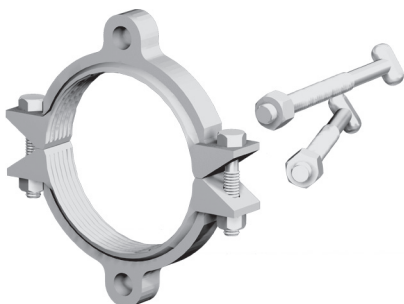

Series 65PF10SS4

Restraint for IPS O.D. (Class) PVC Pipe at
Ductile Iron Fittings



6 5 P F 1 0 S S 4

EBAA IRON SALES, Inc.

P.O. Box 857, Eastland, TX 76448

Tel: (254) 629-1731

Fax: (254) 629-8931

Toll: (800) 433-1716

contact@ebaa.com

www.ebaa.com

Made in the USA