

FLEX-TEND® FLEXIBLE EXPANSION JOINTS, FEATURES AND SPECIFICATIONS

INTRODUCTION

FLEX-TEND® flexible expansion joints are designed to protect structures and pipelines from differential movement whether this movement is earthquake induced or the gradual motion of soil subsidence. This paper is offered as a concise listing and discussion of the important features and materials of the double and single ball assemblies.

GENERAL CONFIGURATIONS

The FLEX-TEND product line is offered in both a double and single ball configuration. Both assemblies provide expansion capacity integral to the deflection capability of the ball and socket. These units are available in the 3" through 36" nominal size range. All FLEX-TEND assemblies are capable of a minimum 15° deflection per ball joint as well as having variable expansion capacity.

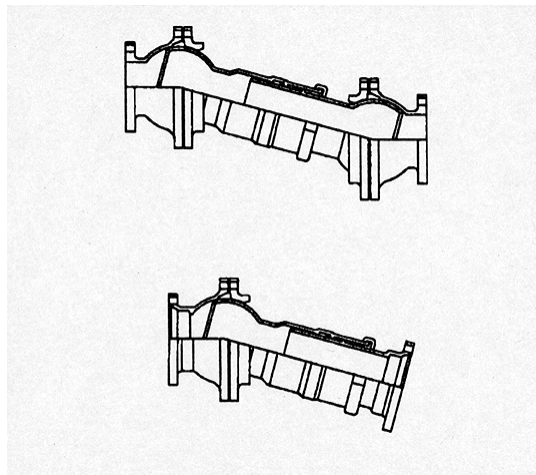

The double ball FLEX-TEND joint provides shear relief for connections to structures with its ability to offset in any plane. This is accomplished by the use of two ball and socket pairs separated by an expansion joint. As the offset motion occurs, the expansion joint provides the required increase in length, thus relieving axial strain on the line and structure. This configuration has been used successfully on connections to tanks, buildings, bridges, and other structures.

The single ball FLEX-TEND assembly is applicable on installations where protection from bending moments and axial strains is warranted. As the name

suggests, this assembly consists of one ball and socket pair with an integral expansion joint. When used in installations such as pipelines crossing soils subject to subsidence or liquefaction, the rotation of the ball acts to relieve bending stress while the expansion joint provides the necessary increase in length. If shear relief beyond the capability of a standard double-ball configuration is needed, two single ball units separated by a sufficient length of pipe is an option.

As seen in the accompanying line drawing, the single and double ball configurations have many components in common. The following discussion of materials and construction is applicable to both with exceptions noted.

FEATURES

After the completion of the FLEX-TEND assembly process and visual inspection, each assembly is hydrostatically tested to its rated pressure of 350 psi in the 3" through 24" sizes, and 250 psi in the larger sizes. The unit is then cleaned, the exterior coating touched up, and banded to a shipping skid. After another inspection, a set of installation instructions and any gaskets needed for the end connections are placed inside. Also included is an eight mil. polyethylene tube for buried applications. The use of the polyethylene cover not only offers corrosion protection, but also reduces the soils frictional resistance to movement. An end cover is then added for protection during shipping and a sticker showing the units model number and other information is applied for the convenience of the user.

Although the FLEX-TEND joint has the capacity for considerable movement, it is also similar to other pipeline fittings in many ways. The unit is suitable for direct bury without the need of a vault. In some cases, the use of a vault. In some cases, the use of a vault or similar structure may impede the motion of the assembly. If future monitoring of the unit is required, or the use of the vault is necessary, the design also be such that it does not hinder the performance of the assembly.

Another similarity between the FLEX-TEND joint and an ordinary fitting is that routine maintenance is not required. There are no packaging chambers to adjust and no pressurized seals to refill. Install it, bury it, and forget it, the unit is designed to be trouble free.

COATINGS

All pressure containing components, wetted surfaces, and seal contact surfaces are coated with a minimum of 15 mils of fusion bonded epoxy. This coating complies with the material requirements of ANSI/AWWA C213 and is holiday free as tested by a 1500 volt spark test per C213. This coating extends to the exterior of the ball so that future motion of the ball joint is not impeded by corrosion.

END CONNECTIONS

The standard end connections of the FLEX-TEND joint are the mechanical joint and flange. Mechanical joint end connections conform to ANSI/AWWA C111/A21.11. Installation follows that of ANSI/AWWA C600 which is the standard for the installation of all mechanical joint pipe and fittings.

Flanged end connections follow the dimensions of ANSI/AWWA C110/A21.10 which is the same template as ANSI B16.5 class 150 without the raised face. An o-ring groove is machined into the face of the flange and an o-ring is supplied for a more positive seal than that of standard flange gaskets.

To enable the FLEX-TEND joint to absorb motion, it must be restrained to the adjacent piping. All other joints and fittings within the area must also be restrained. EBAA Iron produces a wide variety of restraining materials and our sales personnel are pleased to be of assistance in selecting the proper device.

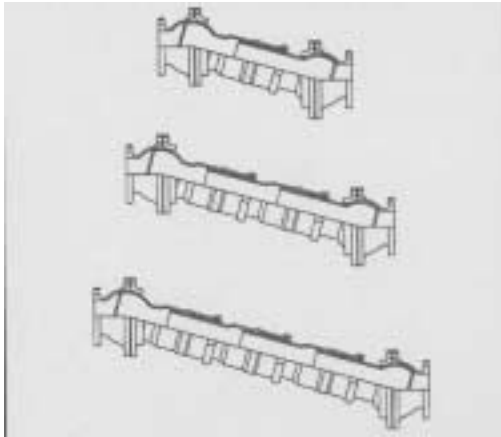

EXPANSION

The expansion capacity of the FLEX-TEND assembly can be varied between 4" and 12" on the 3" through 12" sizes in increments of 4". The 14" through 24" sizes can be provided with 8" to 24" of expansion in 8" increments. The larger sizes have a standard of 10" expansion travel. The increase in

expansion capacity is accomplished by the addition of expansion sleeves. Although more easily inserted during initial assembly, these sleeves can also be added in the field at a later date. An important aspect of the addition of expansion sleeves is the associated increase in the distance between the centerlines of the ball joints. This increase in length offers a considerable increase in the offset capability of the double ball configuration.

One of the important features of the double ball FLEX-TEND is the incorporation of the expansion joint between the flexible ball joints. This expansion joint, like all expansion joints, acts as a hydraulic cylinder when under pressure. The thrust force generated must be accommodated and can be done by the use of external thrust blocks or other structural considerations.

MATERIALS

IRON

The entire FLEX-TEND product line, including pressure vessels and end connections, is cast of Ductile Iron. This material meets or exceeds the requirements of ASTM A536 minimum 60-42-10, as well as the applicable material requirements of ANSI/AWWA C153/A21.53. Iron chemistry, grain structure, as well as physical properties are closely monitored during the casting process. With its elongation capacity, Ductile Iron shares many properties of steel and is not to be confused with the relatively weak and brittle characteristics of gray cast iron.

SEALS

The standard elastomer for the assembly of the FLEX-TEND line is SBR (styrene-butadiene) meeting the applicable material requirements of ANSI/AWWA C111/A21.11. Other materials are available for special applications.

SUMMARY

The attributes of the FLEX-TEND line of flexible expansion joints makes this system ideally suited to the protection of both pipelines and structural connections. Although the benefits are obvious in the mitigation of earthquake damage, the system is not limited to just seismic protection. Pipelines crossing landfills, swamps, and tidal marshes can be protected. Connections to pile supported structures with unsupported piping can also benefit. We invite you all to call the engineering department at EBAA Iron to discuss your application needs.

This is one of a series of CONNECTIONS reports addressing design and application subjects. If you would like copies of other reports or a listing of available reports contact your EBAA Iron representative or call EBAA Iron Sales at (800) 433-1716 or fax (254) 629-8931. EBAA's engineering group can be reached at (800) 633-9190 or fax (254) 629-2079.

Copyright © 1994 EBAA IRON SALES, INC.

P.O. Box 857, Eastland, Texas 76448 USA PHONE: (254) 629-1731 CALL TOLL
FREE: 800-433-1716 TELEFAX: (254) 629-8931
contact@ebaa.com <http://www.ebaa.com>