

Series 65MJ00

Mechanical Joint Restraint
for IPS O.D. (Class) PVC Pipe

Features and Applications:

- For use on IPS O.D. (Class) ASTM D2241 PVC Pipe Systems to restrain mechanical joints
- **MEGA-BOND®** Coating System
For more information on MEGA-BOND, visit our website at www.ebaa.com
- Minimum 2 to 1 Safety Factor
- Split design for ease of installation
- Constructed of A536 Ductile Iron

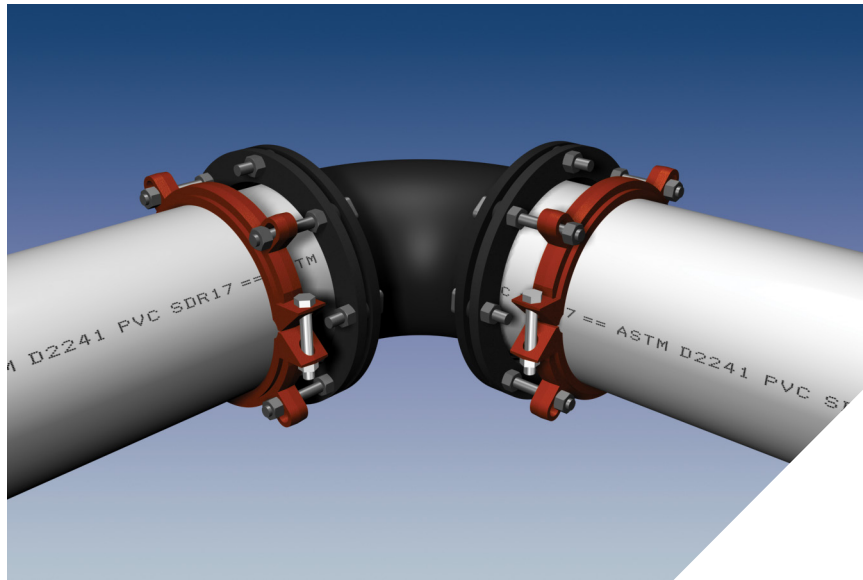

Series 65MJ12 restraining a mechanical joint fitting with a mechanical joint gland.

For use on water or wastewater pipelines subject to hydrostatic pressure and tested in accordance with either AWWA C600, C605 or ASTM D2774.

Nominal Pipe Size	Series Number	Approximate Shipping Weight	Pressure Ratings (PSI)		
			SDR17	SDR21	SDR26
4	65MJ04	10.24	250	200	160
6	65MJ06	14.24	250	200	160
8	65MJ08	18.74	250	200	160
10	65MJ10	32.68	250	200	160
12	65MJ12	36.08	250	200	160

NOTE: For applications or pressures other than those shown, please contact EBAA for assistance. Derate pressure rating if not all connecting bolts are used.

Restraint Ring Tooth Impressions on PVC Pipe.



Sample Specification

Restraint for mechanical joints on IPS O.D. (Class) PVC pipe systems shall consist of the following: The restraint shall be manufactured of ductile iron conforming to ASTM A536. A split serrated ring shall be used to grip the pipe in conjunction with a sufficient number of bolts connecting the serrated restraint to the joint and mechanical joint gland. The combination shall have a pressure rating as mentioned in the most current product brochure. The restraint devices shall be coated with MEGA-BOND. (For complete specifications on MEGA-BOND visit www.ebaa.com.) The restraint for mechanical joint fittings shall be the Series 65MJ00, as manufactured by EBAA Iron, Inc., or an approved equal.

Submittal Reference Drawing

EBAA IRON

MADE IN USA

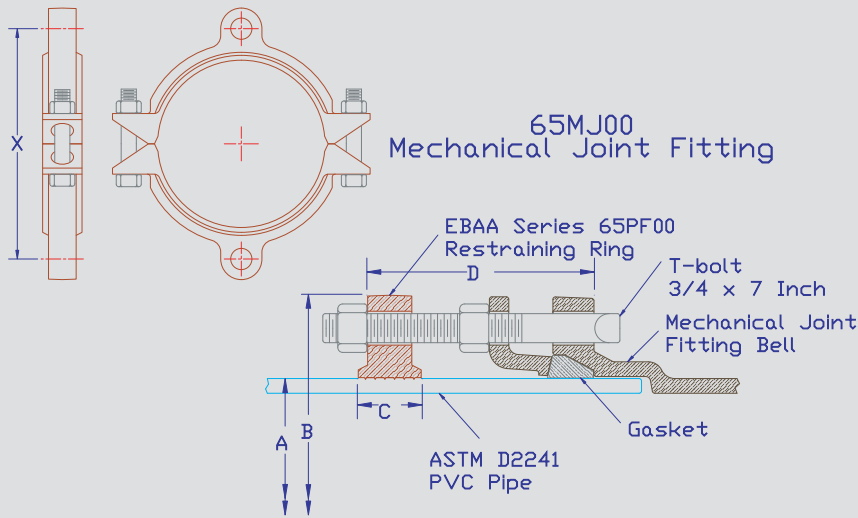

Nominal Pipe Size	Series Number	A Pipe O.D.	B Max. Restraint O.D. (casing clearance)	C Restraining Ring Width	D Restraining Ring Location	* Thrust Bolt Quantity	X Thrust Bolt Circle (Min. - Max.)
4	65MJ04	4.50	9.26	1.25	6	2	7.44
6	65MJ06	6.63	11.20	1.59	6	2	9.50
8	65MJ08	8.63	15.06	1.63	6	2	11.32 - 13.36
10	65MJ10	10.75	16.85	1.93	6	4	13.48 - 15.00
12	65MJ12	12.75	19.45	2.15	6	4	15.94 - 17.66

NOTE: Dimensions are in inches \pm 1% and are subject to change without notice.

*Derate pressure rating if not all connecting bolts were used.

Installation Instructions

1. Identify the pipe. The Series 65MJ00 is designed for restraining IPS (Class) PVC pipe at ductile iron Mechanical Joint (MJ) fittings with MJ glands (supplied by others). The restraint is a split, serrated ring installed behind the MJ gland. The 65MJ00 utilizes longer t-Bolts than the standard MJ t-Bolt lengths to facilitate the restraint position.

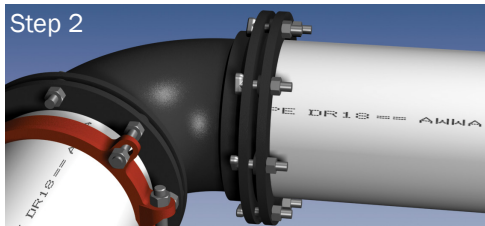

2. Set aside the split restraint and longer bolts and install the MJ gland per AWWA C600. The bolt torques for 4 inch through 12 is 75-90 ft-lbs. The use of a torque-indicating wrench will facilitate the procedure.



3. Using a longer bolt as a gauge, place one half of the restraint onto the pipe so the bolt holes of the restraint and the MJ gland align. Allow enough room on the longer bolts to fully engage the nuts with several threads showing.

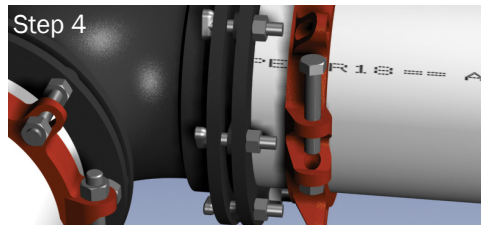

4. Install the second half of the restraint to align with the first. Tapping each half into place may be necessary. Before installing the side bolts double check the position by using the longer bolts as gauges. Make sure the ID of the restraint is touching the pipe. Side bolts are to be evenly tightened to 120 ft-lbs of torque (70 ft-lbs on 4 inch and 6 inch). A torque indicating wrench will help facilitate this.



5. Each of the longer bolts should have two nuts: one to tighten against the MJ gland and one to snug up against the restraint ring with a few threads showing. One at a time, remove a shorter bolt that aligns with the restraint bolt hole and replace with the longer bolt, remembering to "run" one nut up to engage against the MJ gland. This nut should be to the same torque as the original one removed (see step 2 for torque values). Do this for all remaining bolts holes of the restraint.

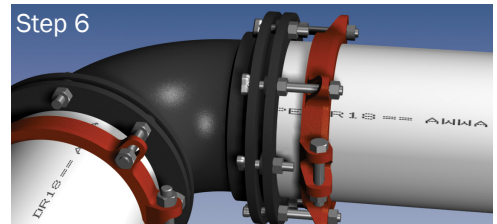

6. Once all bolts are in place and the MJ gland nuts have been retightened to torque, put the remaining nuts on the bolt behind the restraint. Hand tighten the nuts behind the restraint to move the plain-end of the pipe further into the joint.

EBAA IRON Sales, Inc.

P.O. Box 857, Eastland, TX 76448

Tel: (254) 629-1731

Fax: (254) 629-8931

(800) 433-1716 within US and Canada

contact@ebaa.com

www.ebaa.com

